

5301273

MODEL: ATV-25-700

12 VOLT - 25 GALLON LAWN & GARDEN SPRAYER - FOR ATV MOUNTING W/ 7 NOZZLE BOOM ASSEMBLY

ASSEMBLY / OPERATION INSTRUCTIONS / PARTS

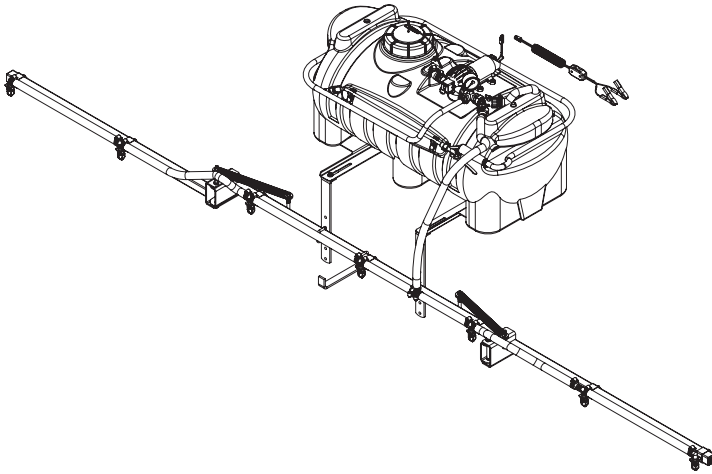

GENERAL INFORMATION

The purpose of this manual is to assist you in operating and maintaining your ATV mounted sprayer. Please read it carefully as it furnishes information which will help you achieve years of dependable trouble free operation.

WARRANTY / PARTS / SERVICE

Products are warranted for one year from date of purchase against manufacturer or workmanship defects.

Your authorized dealer is the best source of replacement parts and service. To obtain prompt, efficient service, always remember to give the following information:

1. Correct part description and part number.
2. Model Number of your sprayer.
3. Serial Number of your sprayer.

Part description and part numbers can be obtained from the illustrated parts list section of this manual.

Whenever you need parts or repair service, contact your distributor / dealer first. For warranty work always take your original sales slip, or other evidence of purchase date, to your distributor / dealer.

TECHNICAL SPECIFICATIONS

- Corrosion Resistant Polyethylene Tank.
- 12 Volt Diaphragm Pump - Demand Switch.
- 2.1 G.P.M.
- Pressure Gauge-Adjustable Pressure Range.
- Handgun w/ Adjustable Nozzle
- 15 Foot Handgun Hose.
- 7 Nozzle Boom Assembly
- 140" Spray Coverage
- Corrosion Resistant Nozzles

CAUTION: Always check the vehicle load rating before using this sprayer. The loaded weight of the sprayer and boom assembly is about 275 lbs. when the tank is full. Care must be taken not to tip the vehicle over backwards, especially when starting or accelerating.

ASSEMBLY

This sprayer is partially assembled at the factory. Assembly may be completed by following these steps.

1. Install all parts of the boom assembly to the boom brackets as shown in the exploded view drawing.
2. Attach the tank to the brackets loosely as shown in the exploded view drawing.
3. Place the sprayer onto the carrier rack of the ATV. Use the u-bolts and hardware to secure the tank mount to the rack.
4. Connect the boom mounting brackets to the tank mounting brackets with hardware provided as shown. Now tighten all bolts and nuts. The nozzle tips should be approximately 18" above the spraying surface.
5. Connect the wiring from the pump to the 12 volt power source of the vehicle. The red wire of the two wire set must be connected to the positive post on the battery or the "Hot" connection on a switch or to the ammeter. The brown wire may be grounded or connected to the negative battery post.
6. The pressure gauge is shipped in a parts bag. Thread the gauge into the tee fitting as shown on the exploded view drawing.

Read the operating instructions and then run the sprayer using only water for testing. When everything tests all right, add the desired chemical mixture and water combination and start the spraying operation.

Always fill the tank with a desired amount of water first, and then add the chemical slowly mixing as you pour the chemical into the tank. You may use the handgun to spray into the solution in order to mix the chemical and water.



WWW.FIMCOINDUSTRIES.COM

1000 FIMCO LANE • P.O. BOX 1700 • NO. SIOUX CITY, SD 57049
TOLL FREE: 800-831-0027 • TOLL FREE FAX: 800-494-0440
Form No. 745 (5004583 6/06) Printed In U.S.A.

Initially begin spraying by opening the handgun. This will enable the air in the line to be eliminated through the tips, while building pressure.

OPERATION

The pumping system draws solution from the tank, through the strainer, and to the pump. The pump forces the solution under pressure to the handgun or boom nozzles.

Pressure may be decreased by opening the bypass valve to the tank. When it is closed the highest spraying pressure will be reached.

- Open the handgun by squeezing the handle lever
- Rotating the adjustable nozzle tip on the handgun will change the tip from a straight stream to a cone pattern (finer mist). Be sure the thumb nut on the adjustable nozzle is tight.
- The pump motor's demand switch shuts off the motor when the handgun, bypass line and boom lines are fully closed. The system remains pressurized, and the pump motor will restart automatically when the handgun, bypass line or boom line is opened. Pump also equipped with manual on-off rocker switch.

ADJUSTING PRESSURE

- By closing the bypass valve pressure is increased to the boom.
- Opening the valve will decrease pressure to the boom.

USING THE BOOM NOZZLES

- Four things must be considered before spraying with the boom.
 1. How much chemical must be mixed in the tank.
 2. Rate of spray (gallons per acre to be sprayed).
 3. What pressure (P.S.I.) will be used.
 4. Speed traveled (M.P.H.) while spraying.
- Refer to the chemical label to determine the chemical mixture.
- See the tip chart to determine the pressure to be used. The chart will also show the speed used when spraying.

CALIBRATION

Chemical labels may show application rates in gallons per acre, gallons per 1000 square feet, or gallons per 100 square feet. You will note that the tip chart below shows all three of these rating systems.

Once you know how much you are going to spray then determine (from the tip chart) the spraying pressure (PSI), and the spraying speed (MPH).

RATE CHART FOR 8002 SPRAY TIP

Pressure P.S.I.	Capacity G.P.M.	Gallons Per Acre Based on Water - 20" Spacing						
		1 MPH 88 FPM	2 MPH 176 FPM	3 MPH 264 FPM	4 MPH 352 FPM	5 MPH 440 FPM	7.5 MPH 660 FPM	10 MPH 880 FPM
20	.14	41.8	20.9	14.0	10.5	8.4	5.6	4.2
30	.17	51.2	25.6	17.2	12.9	10.3	6.9	5.1
40	.20	59.2	29.6	19.8	14.9	11.9	7.9	5.9
50	.23	66.4	33.2	22.2	16.6	13.3	8.8	6.6

20	.14	Gallons Per 1000 Sq. Ft. Based on Water - 20" Spacing						
		.96	.48	.32	.24	.19	.13	.10
30	.17	1.18	.59	.39	.30	.24	.16	.12
40	.20	1.36	.68	.45	.34	.27	.18	.14
50	.23	1.52	.76	.51	.38	.31	.20	.15

20	.14	Gallons Per 100 Sq. Ft. Based On Water - 20" Spacing						
		.095	.048	.032	.024	.019	.012	.009
30	.17	.117	.059	.039	.029	.024	.015	.011
40	.20	.135	.068	.045	.034	.027	.018	.013
50	.23	.152	.076	.050	.038	.030	.020	.015

MPH = Miles Per Hour
 FPM = Feet Per Minute
 PSI = Pounds Per Square Inch
 GPM = Gallons Per Minute

MEASURING TRAVEL SPEED

Measure a test course in the area to be sprayed or in an area with similar surface conditions. Lengths of 100, 200, & 300 ft. are recommended for measuring speeds from 1-10 mph respectively. Determine the time required to travel the test course. To help insure accuracy, conduct the speed check with a loaded sprayer and select the engine throttle setting and gear that will be used when spraying. Repeat the above process and average the times that were measured. Use the following table below to determine ground speed.

Speed Chart

Speed in M.P.H. (Miles Per Hour)	Time Required in Seconds to Travel a distance of;		
	100 ft.	200 ft.	300 ft.
1.0	68	136	205
2.0	34	68	102
3.0	23	45	68
4.0	17	34	51
5.0	14	27	41
6.0	11	23	34
7.0	9.7	19	29
8.0	8.5	17	26
9.0	7.6	15	23
10	6.8	14	20

- Open the "Y" valve to the boom nozzles.
- Check the spray pattern. Usually you can see the coverage better on solid concrete surface, such as a driveway.
- Generally the proper height will be 18 inches from the object being sprayed.

After all calibrations have been completed, add water and chemical to the tank. Always follow chemical manufacturers instructions for mixing.

Conditions of weather and terrain must be considered when spraying chemicals. Do not spray on windy days. Protective clothing must be worn in some cases. **Be sure to read the chemical label carefully.**

Add water and proper amount of chemical to the tank and drive to the starting place for spraying. Adjust pressure to the pressure required. This must be determined from the nozzle tip chart and application rate recommended by the chemical manufacturer. Then start solution spraying from the tips.

If it becomes necessary to clean the screen in the suction line, remove the screen from the end of the intake tube. The screen may now be tapped or flushed with clear water for cleaning.

WARNING: Some chemicals will damage the pump valves if allowed to soak untreated for a length of time. Always flush the pump with water after use. Do not allow chemicals to sit in pump for extended times if idleness. Follow chemical manufacturers instructions on disposal of all waste water from the sprayer.

AFTER SPRAYING

After use fill the sprayer part way with water, start the sprayer and allow clear water to be pumped through the plumbing system and out through the spray nozzles. Refill the tank about half full with plain water and use a

chemical neutralizer such as Nutra-Sol or equivalent and repeat cleaning instructions above. Flush the entire sprayer with the neutralizing agent. Follow the chemical manufacturers disposal instructions of all wash or rinsing water.

Remove tips and screens from the boom. Wash tips thoroughly with water or cleaning solution (appropriate for chemical used). Blow out orifice, clean and dry. If orifice remains clogged, clean it with a fine bristle (not wire) brush, or with a toothpick. Do not damage the orifice. Water rinse and dry tips before storing.

WINTER STORAGE

Drain all water out of sprayer paying special attention to pump, handgun & valve. These items are especially prone to damage from chemicals and freezing weather.

The sprayer should be winterized before storage by pumping a solution of RV anti-freeze through the entire plumbing. Proper care and maintenance will prolong the life of the sprayer.

Exploded View of Pump #5275016

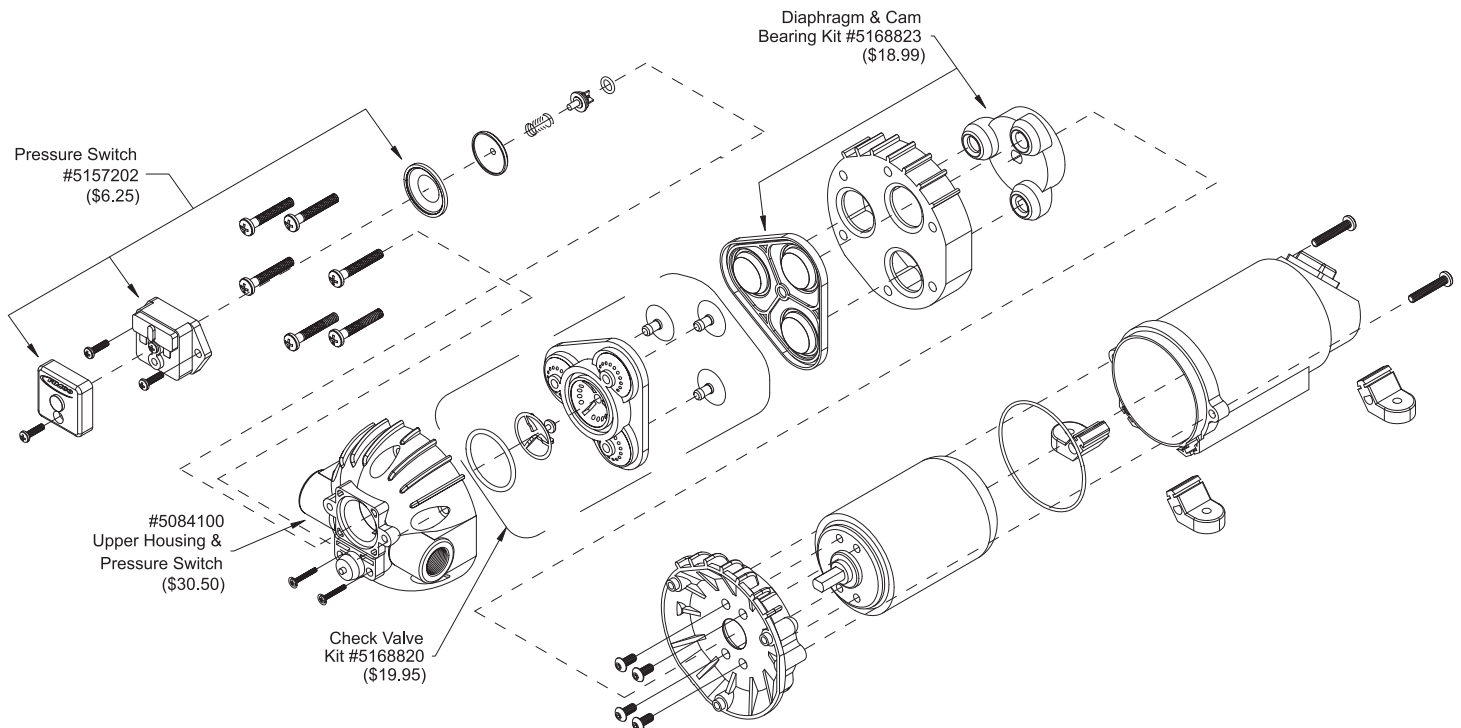

Pump Sub-Assembly #5275147

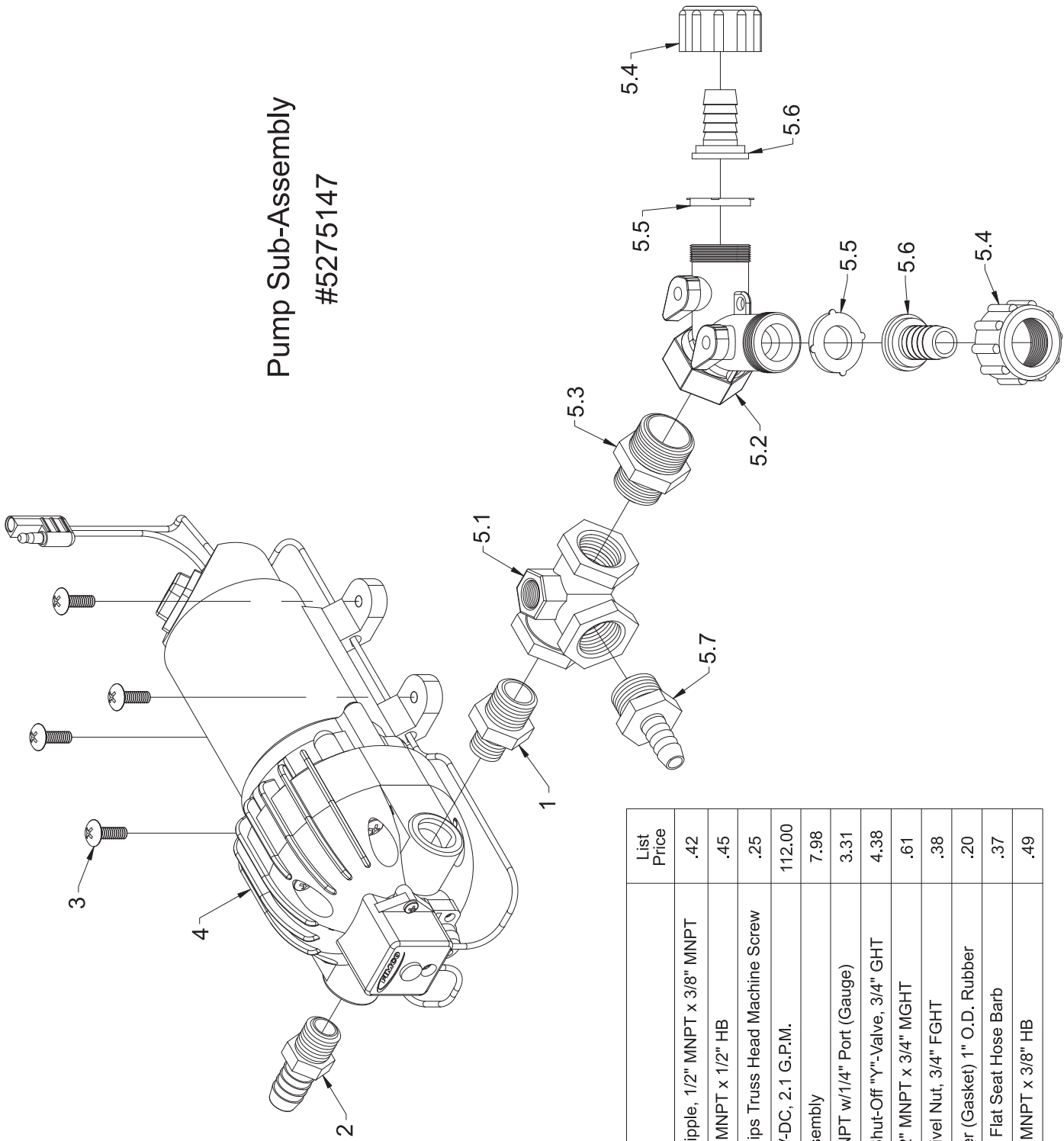

Item No.	Part Number	Qty	Description	List Price
1	5011128	1	Nylon Reducing Nipple, 1/2" MNPT x 3/8" MNPT	.42
2	5067021	1	Nylon Fitting, 3/8" MNPT x 1/2" HB	.45
3	5117167	4	#10-24 x 5/8" Phillips Truss Head Machine Screw	.25
4	5275016	1	Triplex Pump, 12V-DC, 2.1 G.P.M.	112.00
5	5275118	1	Plumbing Sub-Assembly	7.98
5.1	5010193	1	Nylon Tee, 1/2" FNPT w/1/4" Port (Gauge)	3.31
5.2	5143204	1	#235 Dual Hose Shut-Off "Y"-Valve, 3/4" GHT	4.38
5.3	5005021	1	Nylon Adapter, 1/2" MNPT x 3/4" MGHT	.61
5.4	5006055	2	Nylon Knurled Swivel Nut, 3/4" FGHT	.38
5.5	5016066	2	#102 Hose Washer (Gasket) 1" O.D. Rubber	.20
5.6	5149011	2	Nylon Swivel, 1/2" Flat Seat Hose Barb	.37
5.7	5067016	1	Nylon Fitting, 1/2" MNPT x 3/8" HB	.49

Exploded View/Parts List:
ATV-25-700

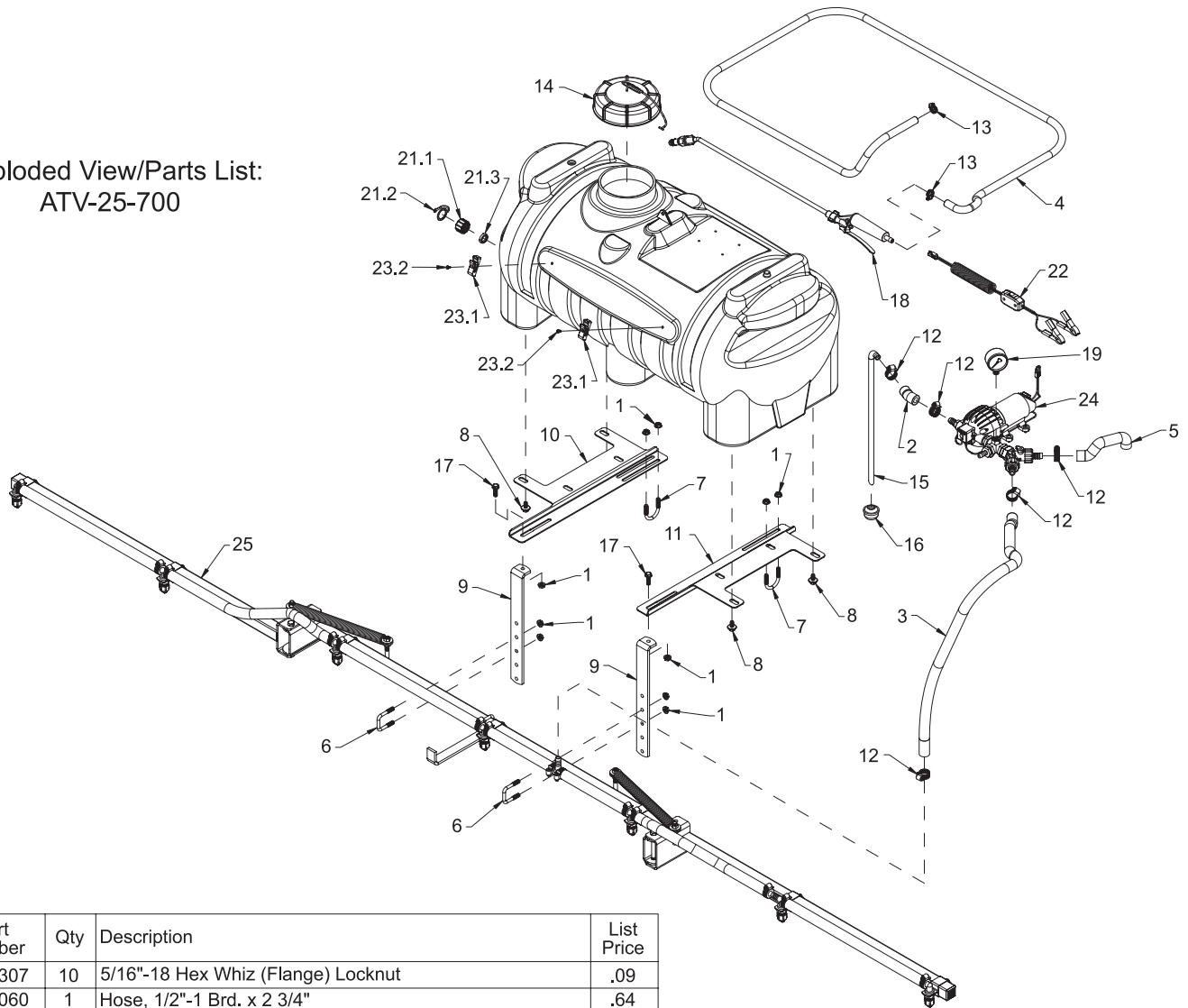

Item No.	Part Number	Qty	Description	List Price
1	5006307	10	5/16"-18 Hex Whiz (Flange) Locknut	.09
2	5020060	1	Hose, 1/2"-1 Brd. x 2 3/4"	.64
3	5020122	1	Hose, 1/2"-1 Brd. x 48"	5.88
4	5020215	1	Hose, 3/8"-1 Brd. x 15 Ft.	8.50
5	5020241	1	Hose, 1/2"-1 Brd. x 6"	1.51
6	5034159	2	Square U-Bolt, 5/16" x 1 5/16" x 1 7/8"	.65
7	5034220	2	Round U-Bolt, 5/16"-18 x 1 5/16" x 1 3/4"	.50
8	5034531	4	5/16"-18 x 5/8" Flange Lock Screw	.44
9	5038506	2	Boom Mounting Bracket	5.75
10	5038667	1	Tank Mounting Plate (15 & 25 Gal.) (L.H.)	11.06
11	5038725	1	Tank Mounting Plate (15 & 25 Gal.) (R.H.)	11.06
12	5051022	5	Hose Clamp, 1/2"	.62
13	5051114	2	Hose Clamp, 3/8"	.63
14	5058183	1	FIMCO 5" Threaded Tank Lid w/Lanyard	10.50
15	5100275	1	Intake Tube (25 Gallon)	1.40
16	5116251	1	Strainer, Suction Line	1.99
17	5117300	2	5/16"-18 x 1" Flange Whiz Lock Screw	.22
18	5163100	1	Low Flow Handgun w/X-26 Adjustable Tip, 29 1/2" Wand	9.95
19	5167007	1	Gauge, 0-100 p.s.i.	5.99
20	5169206	1	25 Gallon Blowmolded Tank (w/2 Holes)	64.95
21	5274373	1	Drain Plug Cap, Tether, and Washer Assembly	2.95
21.1	5102117	1	Drain Plug Cap	.99
21.2	5058171	1	Drain Cap Tether	.30
21.3	5072507	1	Drain Cap Washer	.20
22	5274443	1	Lead Wire Assembly (w/Switch), 96"	13.50
23	5274880	1	Pkg. (2) Handgun Clips & (2) Screws	2.85
23.1	5053096	2	Handgun Clip, for Blow-Molded Tanks	.95
23.2	5117293	2	#10-24 x 3/8" Phillips Round Head Machine Screw	.25
24	5275147	1	Pump Sub-Assembly w/Triplex Pump	127.00
25	BK-70	1	7-Nozzle Boom Assembly	175.00

Exploded View:
BK-70

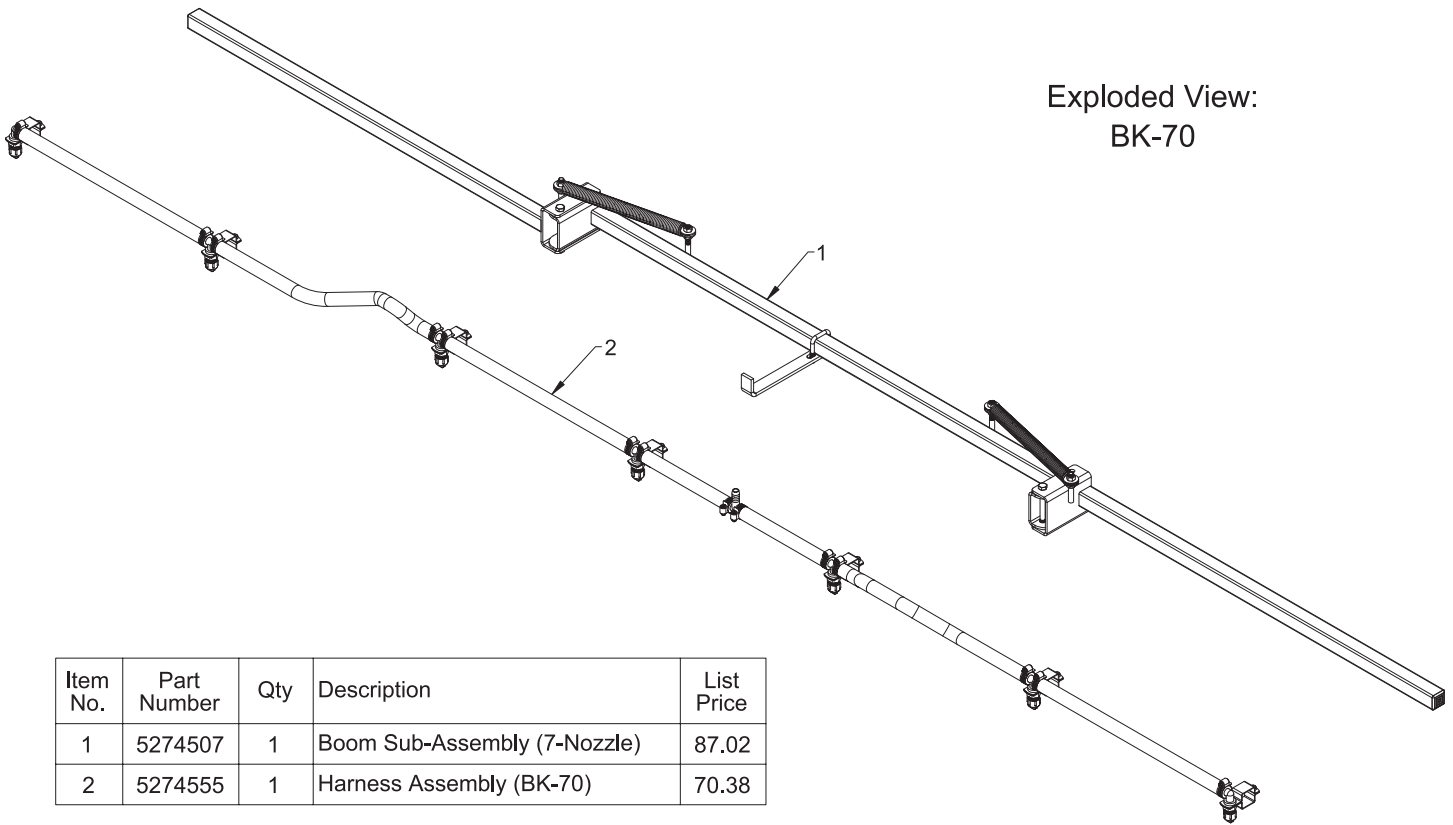

Item No.	Part Number	Qty	Description	List Price
1	5274507	1	Boom Sub-Assembly (7-Nozzle)	87.02
2	5274555	1	Harness Assembly (BK-70)	70.38

Exploded View/Parts List:
Boom Sub-Ass'y #5274507

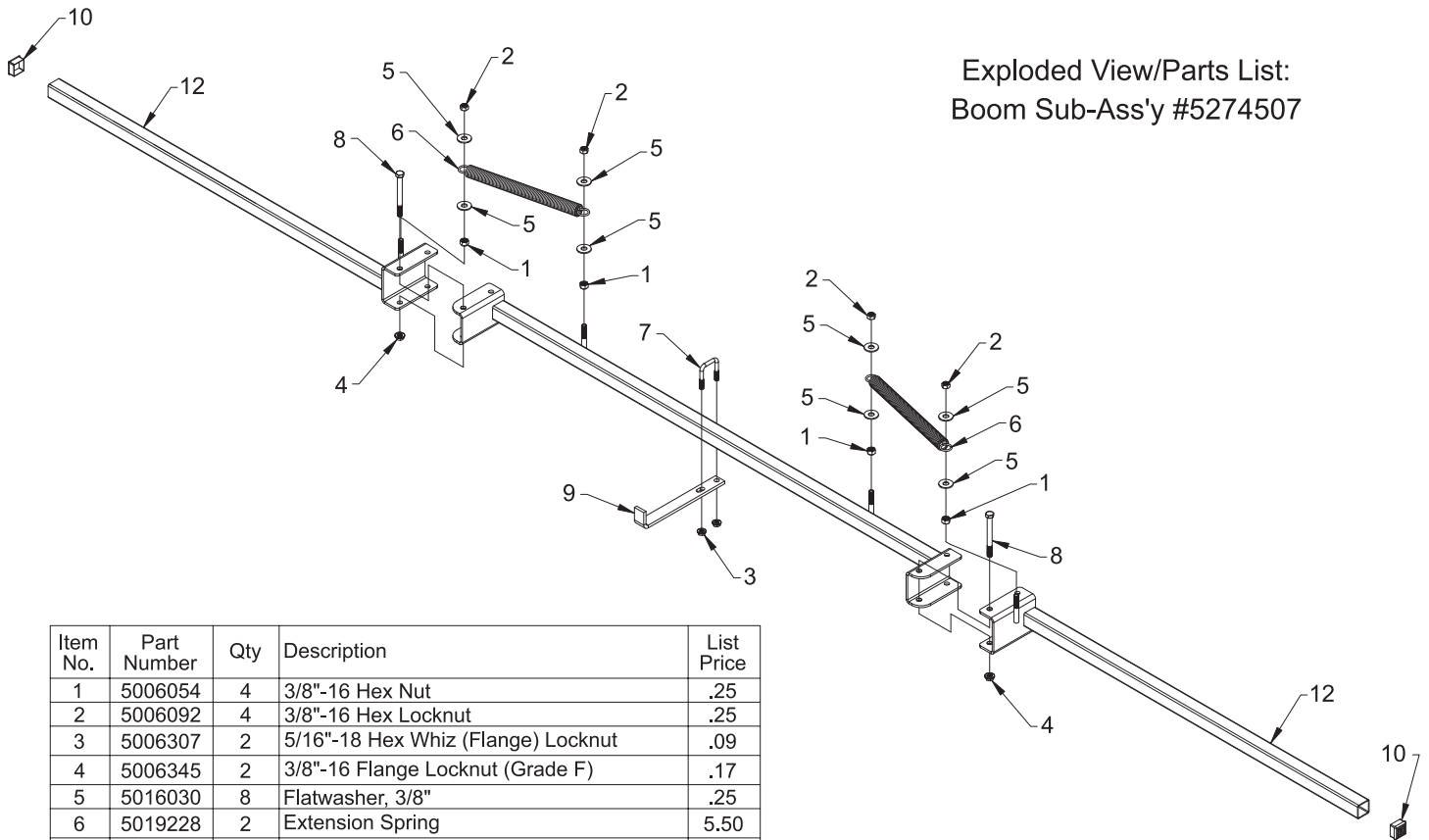

Item No.	Part Number	Qty	Description	List Price
1	5006054	4	3/8"-16 Hex Nut	.25
2	5006092	4	3/8"-16 Hex Locknut	.25
3	5006307	2	5/16"-18 Hex Whiz (Flange) Locknut	.09
4	5006345	2	3/8"-16 Flange Locknut (Grade F)	.17
5	5016030	8	Flatwasher, 3/8"	.25
6	5019228	2	Extension Spring	5.50
7	5034159	1	Square U-Bolt, 5/16" x 1 5/16" x 1 7/8"	.65
8	5034563	2	H.H.C.S., 3/8"-16 X 3 3/4"	.44
9	5038620	1	Boom Retainer Bracket	2.60
10	5046344	2	Square Cap, Black (1 1/4" Square Tube)	.21
11	5274458	1	Center Boom Weldment (BK-70)	24.06
12	5274459	2	Outer Boom Weldment	14.11

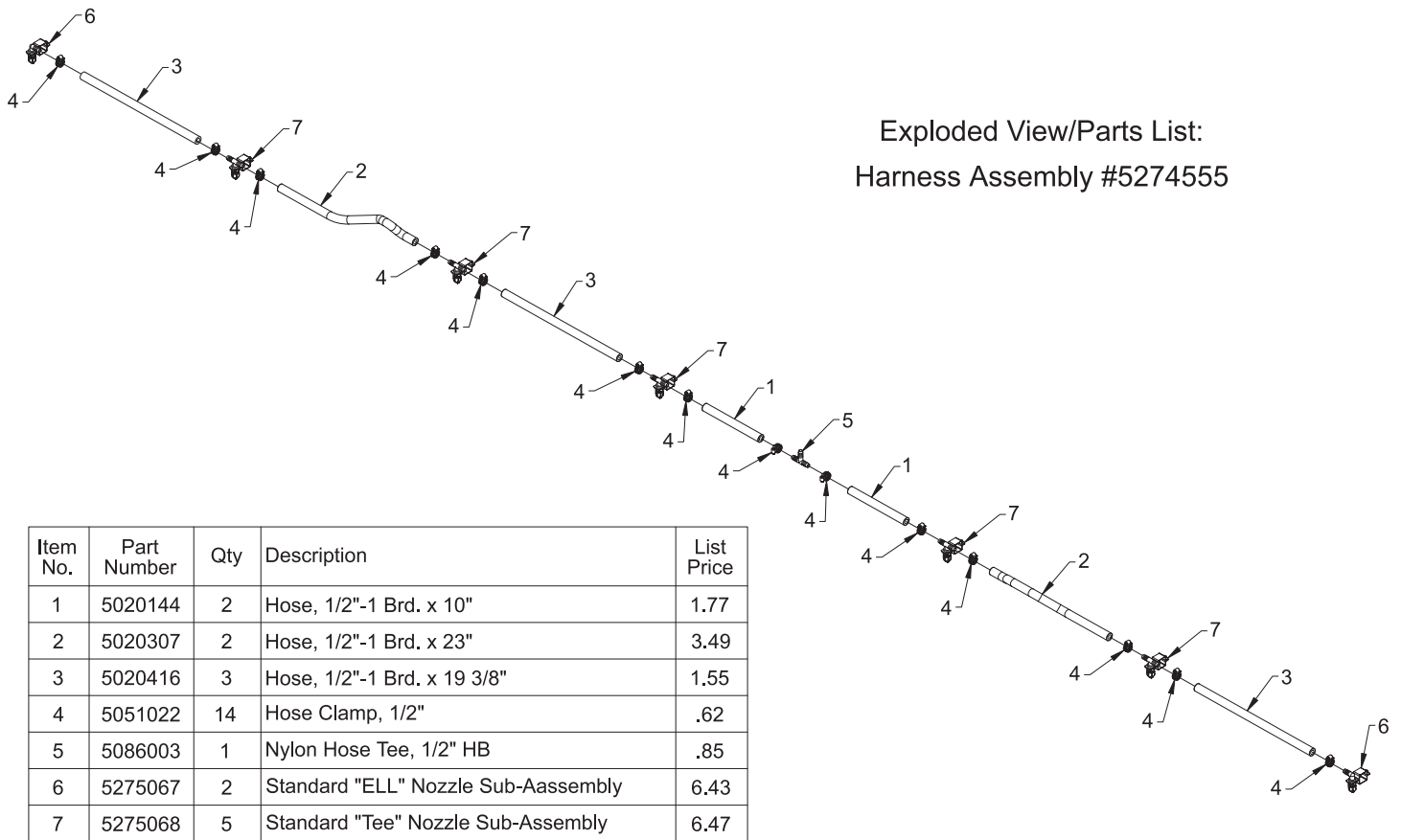

Exploded View/Parts List:
Harness Assembly #5274555

Item No.	Part Number	Qty	Description	List Price
1	5020144	2	Hose, 1/2"-1 Brd. x 10"	1.77
2	5020307	2	Hose, 1/2"-1 Brd. x 23"	3.49
3	5020416	3	Hose, 1/2"-1 Brd. x 19 3/8"	1.55
4	5051022	14	Hose Clamp, 1/2"	.62
5	5086003	1	Nylon Hose Tee, 1/2" HB	.85
6	5275067	2	Standard "ELL" Nozzle Sub-Assembly	6.43
7	5275068	5	Standard "Tee" Nozzle Sub-Assembly	6.47

Nozzle Assembly #5275067

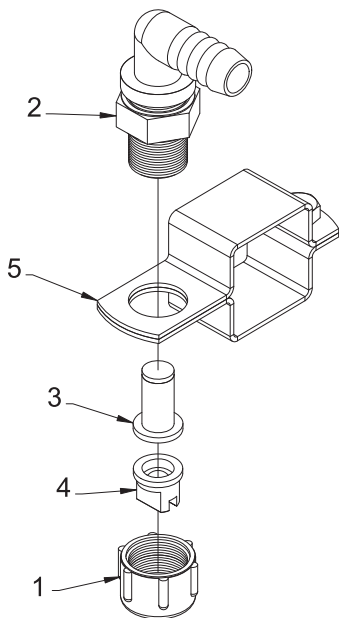

Item No.	Part Number	Qty	Description	List Price
1	5046052	1	Nylon Nozzle Cap, 11/16" U.N.F. Thread	.35
2	5056023	1	Nylon Elbow, 11/16" U.N.F. x 1/2" HB	.79
3	5116019	1	50 Mesh Nozzle Strainer, Red	.93
4	5138571	1	Nylon Standard Flat Tip, 80 Degree, Yellow	.82
5	5273796	1	1 1/4" Square Boom Nozzle Clamp (BC114)	1.70

Nozzle Assembly #5275068

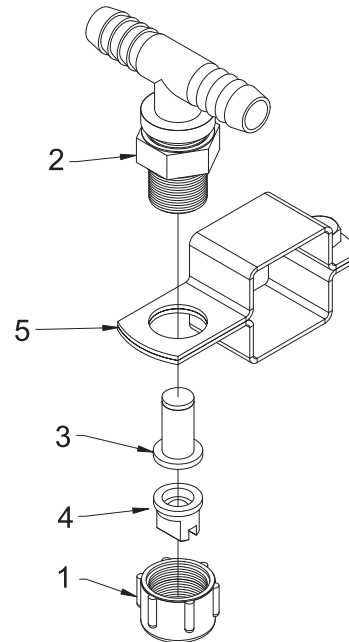

Item No.	Part Number	Qty	Description	List Price
1	5046052	1	Nylon Nozzle Cap, 11/16" U.N.F. Thread	.35
2	5056027	1	Nylon Tee, 11/16" U.N.F. x 1/2" HB-1/2" HB	.83
3	5116019	1	50 Mesh Nozzle Strainer, Red	.93
4	5138571	1	Nylon Standard Flat Tip, 80 Degree, Yellow	.82
5	5273796	1	1 1/4" Square Boom Nozzle Clamp (BC114)	1.70