

ESTATE RAKE™

ASSEMBLY INSTRUCTIONS

- Assembly of your **ESTATE RAKE™** will be very easy and quick if you refer to the instructions and sequence of assembly.
 - First unpack all loose components. Identify and become familiar with them.
1. Find the ½ x 4½ bolt, and assemble the tongue to the main frame using the reversible lock nut. Be sure the 4-hole adjustment plate is positioned to the left of the rake. **Do not** over-tighten this bolt or it will hamper the sideways tongue adjustment. Refer to Item #1 on the Drawing Page.
 2. Place angle adjustment bar in bracket welded to main frame, and install cotter pin to keep it in place. Install the other end into either of the two middle holes in the 4-hole bracket welded to the tongue.
 3. Find the ½ x 5 bolt and lock nut, and assemble the lift arms to the main frame as shown in Item #3 of the Drawing Page. Both of these arms are identical and are reversible. Install them so the lift loops are on top. Tighten this bolt only enough to remove most of the side-play, but to still allow free movement of the arms.
 4. Install the lift handle to the tongue with the turnbuckle-cable facing the rear of the rake. Use the 5/16 x 2 bolts and nuts with the 2-hole plate on the bottom to avoid crushing the tongue. As shown in Item #4 of the Drawing Page. Place the 3/16 x 1 cotter pin in the rear hole of the notch plate to limit the downward travel of the handle.
 5. Place a 5/8 flat washer on each of the main frame axles. Install the tires on the axles with the offset part of the hub against the washer. Secure the tire assemblies to the axles using the 5/8 nylock nuts. **Do not** over-tighten the nuts; 1/32 side play on the bearings will insure they will not lock up or cause premature wear.
 6. Install (2) polymer pulleys using the 7/16 hitch pin and music keeper as shown in Item #5 on the Drawing Page.
 7. Install (2) polymer pulleys on the tower to the right of the first tower. As shown in Item #6. Insert the (2) ¼ x 1 bolts through the galvanized top keeper with two holes. Next put a bushing on each bolt, followed by a pulley on each. Insert the assembly through the

- two holes in the tower and secure with the $\frac{1}{4}$ locking nuts. You may firmly tighten these bolts and check that all pulleys rotate freely.
8. The rear lift cable has (4) loops on it. Begin installing it by passing one end through the pulley on the end of the front lift cable.
 9. Next insert both ends of the cable through the pulley tower located directly in line behind the tongue. Keeping the twists and kinks out, allow one cable to seat in each of the pulleys.
 10. Next pass both ends through the parallel tower to the right.
 11. Checking to see that the cable is not twisted or tangled, take the end of the cable that is best suited to follow the rear pulley and pass the first loop through the spring and fasten it and the spring to the lift arm as shown in Item 7. Hook the second loop to the other end of the spring. Follow the same sequence for the front lift arm.
 12. Both weight boxes are the same, and are punched with (2) sets of mounting holes. The weight box on the left side will need to be mounted with the long dimension of it going in the direction of travel and the right box will mount with the short dimension going in the direction of travel. This configuration will not interfere with the lift cables. You will need to use the $\frac{5}{16} \times \frac{3}{4}$ self-tapping bolts. A slight pressure will be required on them while turning to start the threading action.
 13. You must use weights in the boxes to achieve the correct raking action.
 14. Both 3-wheel pivot arms are the same. Place them in the pivot sockets of the lift arms, and secure them with the lynch pins supplied. The word TOP should be visible on each. For both pivot arms, the end with the long bend should be away from the tongue, and hold the way front and the way back rake wheel.
 15. When placing the rake wheels on the pivot arms arrange them so the nuts holding the center hubs together are facing the front of the rake. Note the wheels will rake when turning either direction, but all of them should be turning the same direction. Tighten the $\frac{5}{8}$ lock nuts allowing approximately $\frac{1}{32}$ side play.

ESTATE RAKE™

DRAWING PAGE

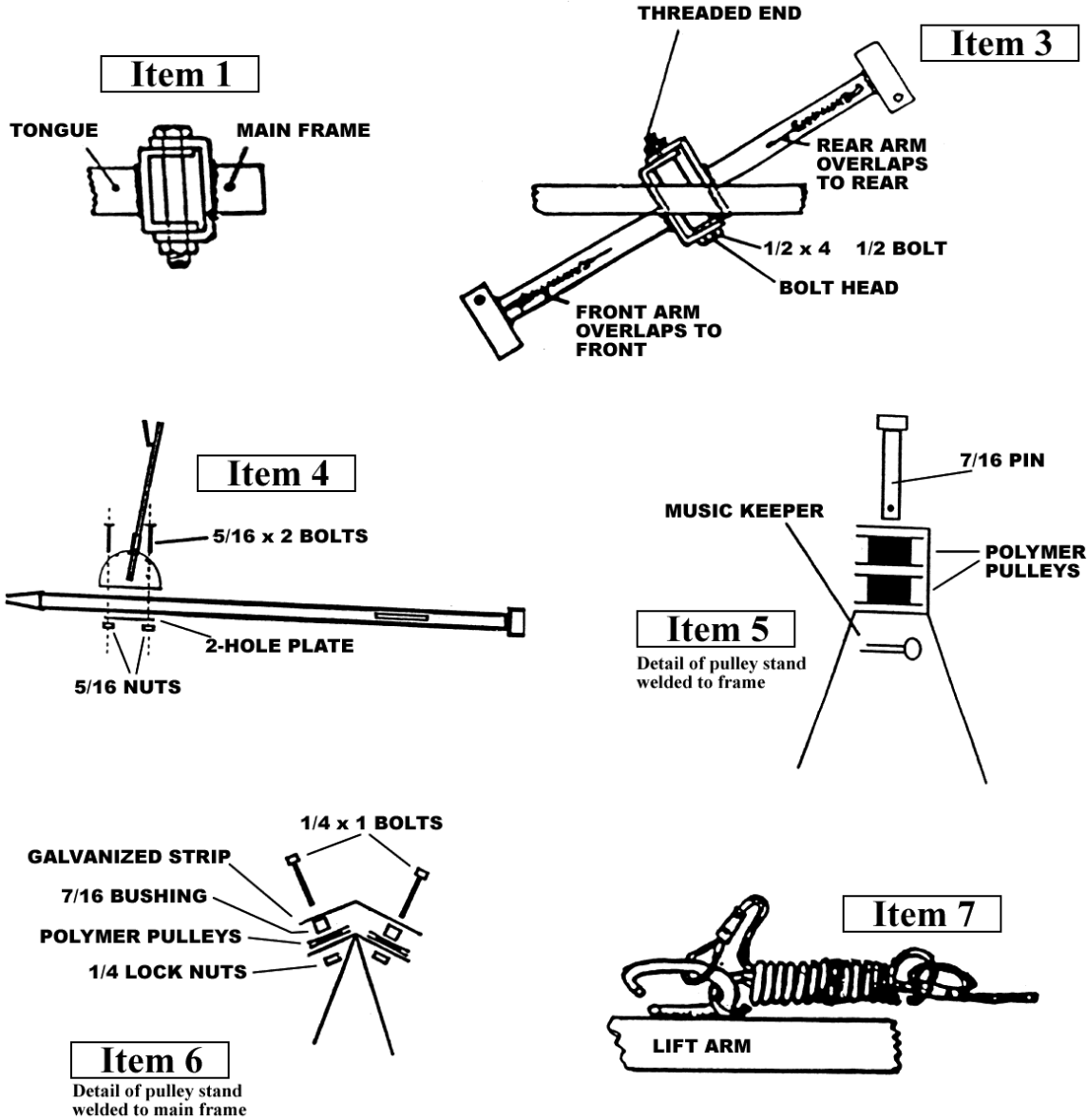

ESTATE RAKE™

ASSEMBLY INSTRUCTIONS

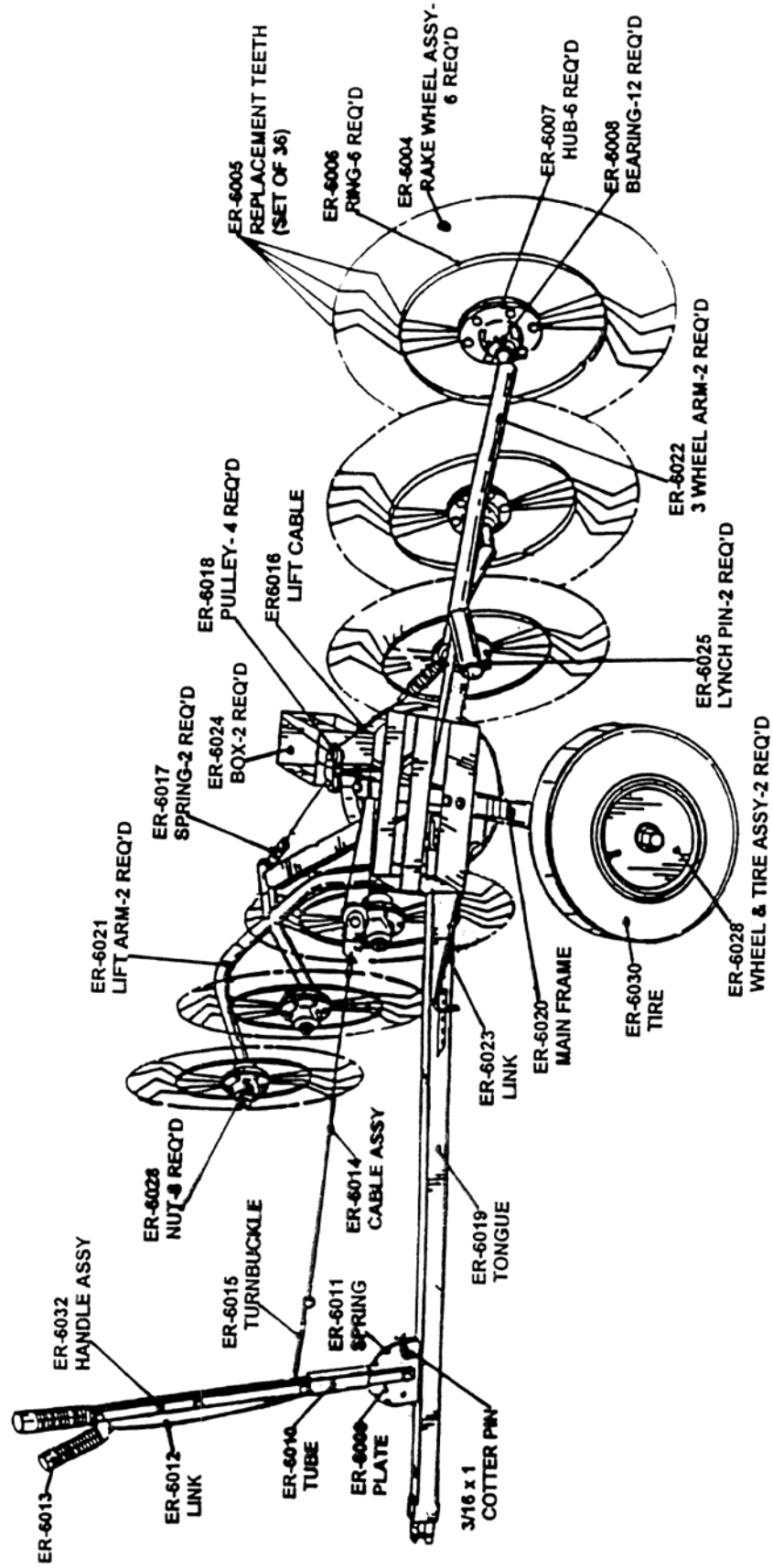

ESTATE RAKE™

OPERATION & CAUTION

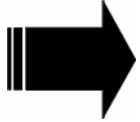

***READ BEFORE USING
ESTATE RAKE™ IS NOT A TOY
CARELESS USE OR MISUSE CAN
RESULT IN SERIOUS INJURY OR DEATH***



1. Estate Rake™ performs best in short grass – mow before raking.
2. **Do not** allow riders or bystanders on or near the operating unit.
3. Maximum towing speed is **4 mph**.
4. Estate Rake™ will tow off to the right of the pulling vehicle, so a constant alertness and caution must be present to avoid damage or injury to items, people, or pets in the area.
5. Always stop and place towing unit in neutral when lifting or adjusting depth of cut on rake.
6. When not in use, always remove the 3-wheel assemblies at the pivot-point and store them in a safe place (use the spring loop pins; no tools required).
7. Weight boxes have been provided and will be required when de-thatching or preparing for under seeding. The boxes will accept (4) standard facing bricks each, or a flat style 1-gallon jug filled with sand or water. The use of weight will add stability, and greatly reduce side-tracking.
8. After some use, the spring steel rake teeth will tend to take a set or bend to the rear: this is normal and can be corrected and controlled by switching the 3-wheel rake assemblies (front to rear – rear to front).

Have a safe summer and a beautiful yard.

THANK YOU